

THIS DRAWING IS UNPUBLISHED. RELEASED FOR PUBLICATION ,19 .
 © COPYRIGHT 19 BY AMP INCORPORATED. ALL RIGHTS RESERVED.

LOC		DIST		REVISIONS			
P	LTR	DESCRIPTION		DATE	DWN	APVD	
G	14	B		REDRAWN PER 0720-0470-95	23JAN95	LO	ME

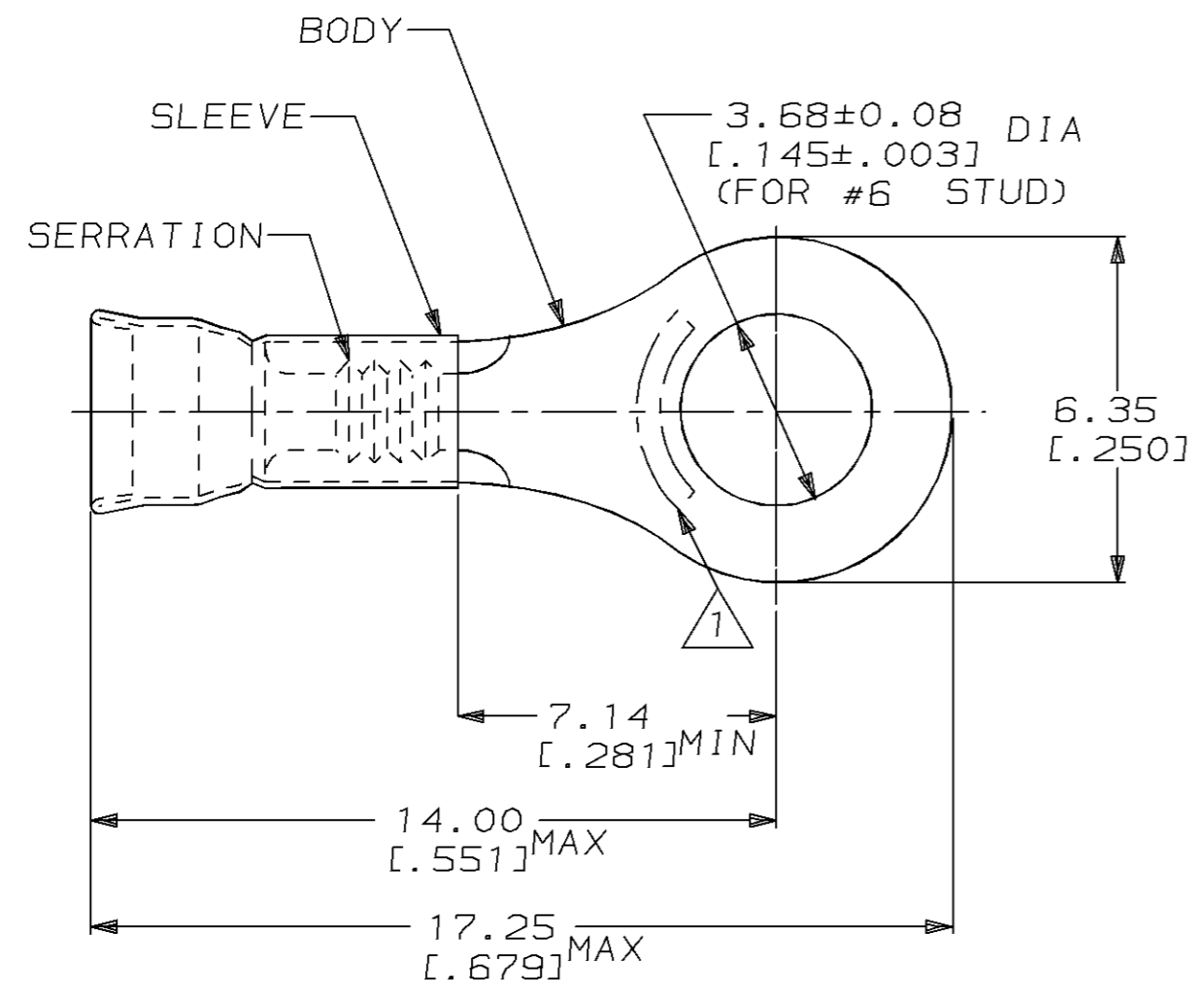

△ 1 STAMP AMP LOCATE APPROX AS SHOWN

- 2. WIRE INSUL DIA, 1.27-2.08 [.050-.082]
- 3. TONGUE MATL THK, 0.46±0.05 [.018±.002]

5000	ON TAPE, REEL	2-32861-2
1000	LOOSE PIECE	32861
QTY	PACKAGE TYPE	PART NO

AMP INCORPORATED CUSTOMER SERVICE SYSTEM		MAX RECOMMENDED OPERATING TEMPERATURE: -	THIS DRAWING IS A CONTROLLED DOCUMENT FOR AMP INCORPORATED. IT IS SUBJECT TO CHANGE AND THE CONTROLLING ENGINEERING ORGANIZATION SHOULD BE CONTACTED FOR THE LATEST REVISION.		DWN L OLMEDA 23JAN95	AMP AMP Incorporated Harrisburg, PA 17105-3608
FOR ADDITIONAL PRODUCT INFORMATION OR COPIES OF DRAWINGS AND TECHNICAL DOCUMENTS	PRODUCT INFORMATION CENTER 1-800-522-6752	VOLTAGE RATING: -	DIMENSIONS: mm [in]	TOLERANCES UNLESS OTHERWISE SPECIFIED:	CHK M ELLIS 23JAN95	
FOR APPLICATION TOOLING INFORMATION	TOOLING ASSISTANCE CENTER 1-800-722-1111	CIRCULAR MIL AREA: 0.10mm ² -0.41mm ² [202-810]		0 PLC ±-	APVD S BORTNER 23JAN95	NAME TERMINAL, RING, DIAMOND GRIP, WIRE SIZE, 26-22 AWG
FOR ORDER ENTRY	1-800-526-5142	STRANDED WIRE		MATERIAL BODY, CU, SLV, CU PER ASTM B152	1 PLC ±- 2 PLC ±0.20 [.008] 3 PLC ±- 4 PLC ±- ANGLES ±-	PRODUCT SPEC -
			FINISH TIN PLATE PER MIL-T-10727		APPLICATION SPEC -	CAGE CODE 00779
CUSTOMER DRAWING					WEIGHT -	DRAWING NO C-32861
					SCALE 6:1	SHEET 1 OF 1
					REV B	